

Description

DF6812E is a high current precision Linear LED Driver, It can be used in TRIAC dimmable LED driver, integrated with High Voltage regulation switchers and JFET supply, specially designed for AC line LED strings forwarded with high voltage and low current.

In application, it supports a quite small BOM benefit from no ECAP and no Magnetics, compile with EMI and safety standard.

DF6812E can drive precision constant current by option of an external resistor, and set up the LED strings in group linear compile with THD performance. Typical 40mA LED current is optimized for 220V line voltage.

Features

- ◆ High integration, all SMTs in small size.
- ◆ No ECAPs and magnetics
- ◆ Integrated with 500V HV MOS, saved on safety components.
- ◆ Fast startup
- ◆ LED current set by external resistors with $\pm 5\%$ accuracy.
- ◆ On chip thermal regulation.
- ◆ Compensation for line regulation
- ◆ In ESOP8 package.

Application

- ◆ GU10/E27 LED retrofit lamps
- ◆ LED candle
- ◆ Other LED lighting

Typical Application

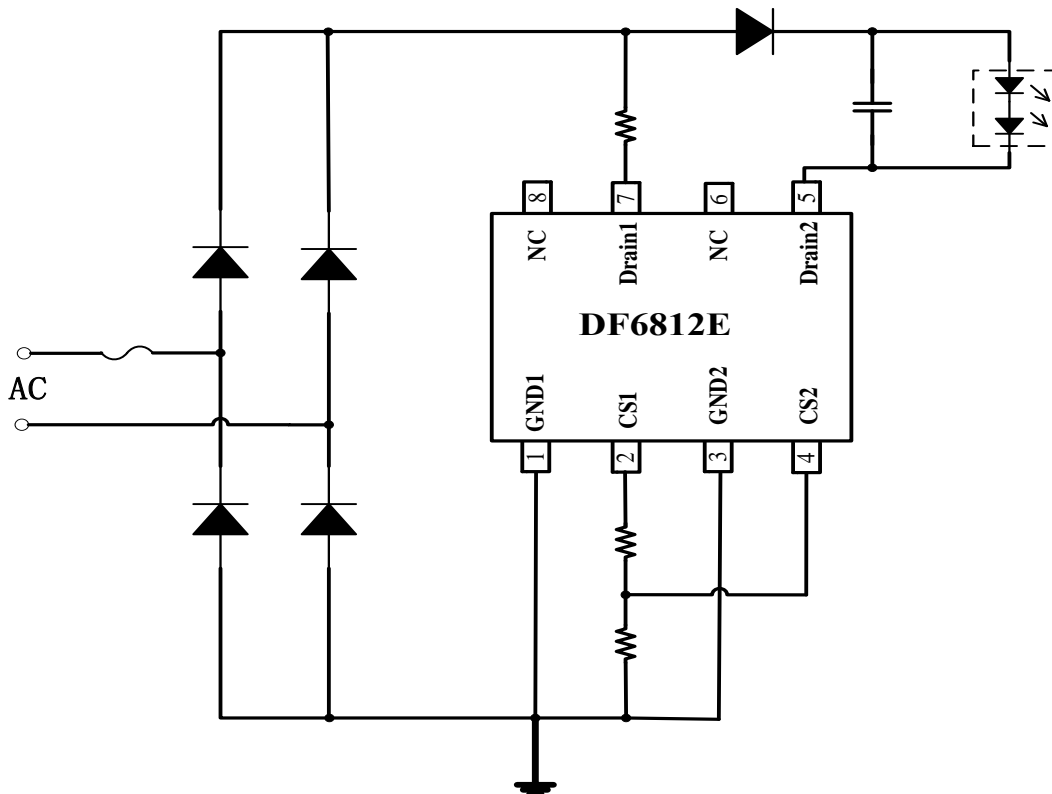

Fig.1 DF6812E Typical Application

Order Information

Part Number	Package	Temperature	Packing Method	Mark
DF6812E	ESOP8	-40 °C to 105 °C	Tape 4000 pcs/reel	DF6812E XXXXXY WXYXC

Pin mapping

XXXXXY: lot code

WX: sign

YY: 周号

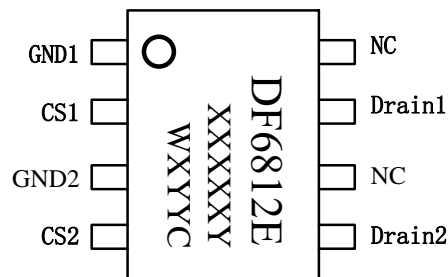

Fig 2 DF6812E Pin Mapping

Pin Descriptions

Pin No.	Pin Name	Descriptions
1	GND1	IC ground 1
2	CS1	Current sense 1, connect the current sense resistor to GND1
3	GND2	IC ground 2
4	CS2	Current sense 2, connect the current sense resistor to GND2
5	Drain2	Drain2 for LED string
6,8	NC	Not connect
7	Drain1	Drain1 for LED string

Absolute Limit (Note1)

Symbol	Parameter	Range	Unit
D	500V HV interface	500	V
I _{D_MAX}	Saturation current @ T _{J_max}	80	mA
CS	Low voltage pins	-0.3~6	V
P _{DMAX}	Power dissipation (note 2)	1	W
θ _{JA}	Thermal Resistor	60	°C/W
T _J	Junction Temperature	-40 to 150	°C
T _{STG}	Storage temperature range	-55 to 150	°C
	ESD (Note 3)	2	KV

Note 1: Stresses beyond those listed under “absolute maximum ratings” may cause permanent damage to the device. Under “recommended operating conditions” the device operation is assured, but some particular parameter may not be achieved. The electrical characteristics table defines the operation range of the device, the electrical characteristics is assured on DC and AC voltage by test program. For the parameters without minimum and maximum value in the EC table, the typical value defines the operation range, the accuracy is not guaranteed by spec.

Note 2: The maximum power dissipation decrease if temperature rise, it is decided by T_{JMAX}, θ_{JA}, and environment temperature (T_A). The maximum power dissipation is the lower one between P_{DMAX}= (T_{JMAX}-T_A)/ θ_{JA} and the number listed in the maximum table.

Note 3: Human Body mode, 100pF capacitor discharge on 1.5KΩ resistor

Electrical Characteristics (note4, 5) (unless specified, otherwise $T_A=25\text{ }^\circ\text{C}$)

Symbol	description	Test condition	Min.	Typ.	Max.	UNIT
Operation Current						
I_{CC}	Operation current	D=30V		180	320	uA
Current Sense						
V_{REF}	Ref. for string1	D=30V, $R_{cs}=120\Omega$		600		mV
Thermal Regulation						
T_{REG}	Thermal Regulation			150		$^\circ\text{C}$

Note 4: Production testing of the chip is performed at 25°C. **Note 5:** The maximum and minimum parameters specified are guaranteed by test, the typical value are guaranteed by design, characterization and statistical analysis

Block Diagram

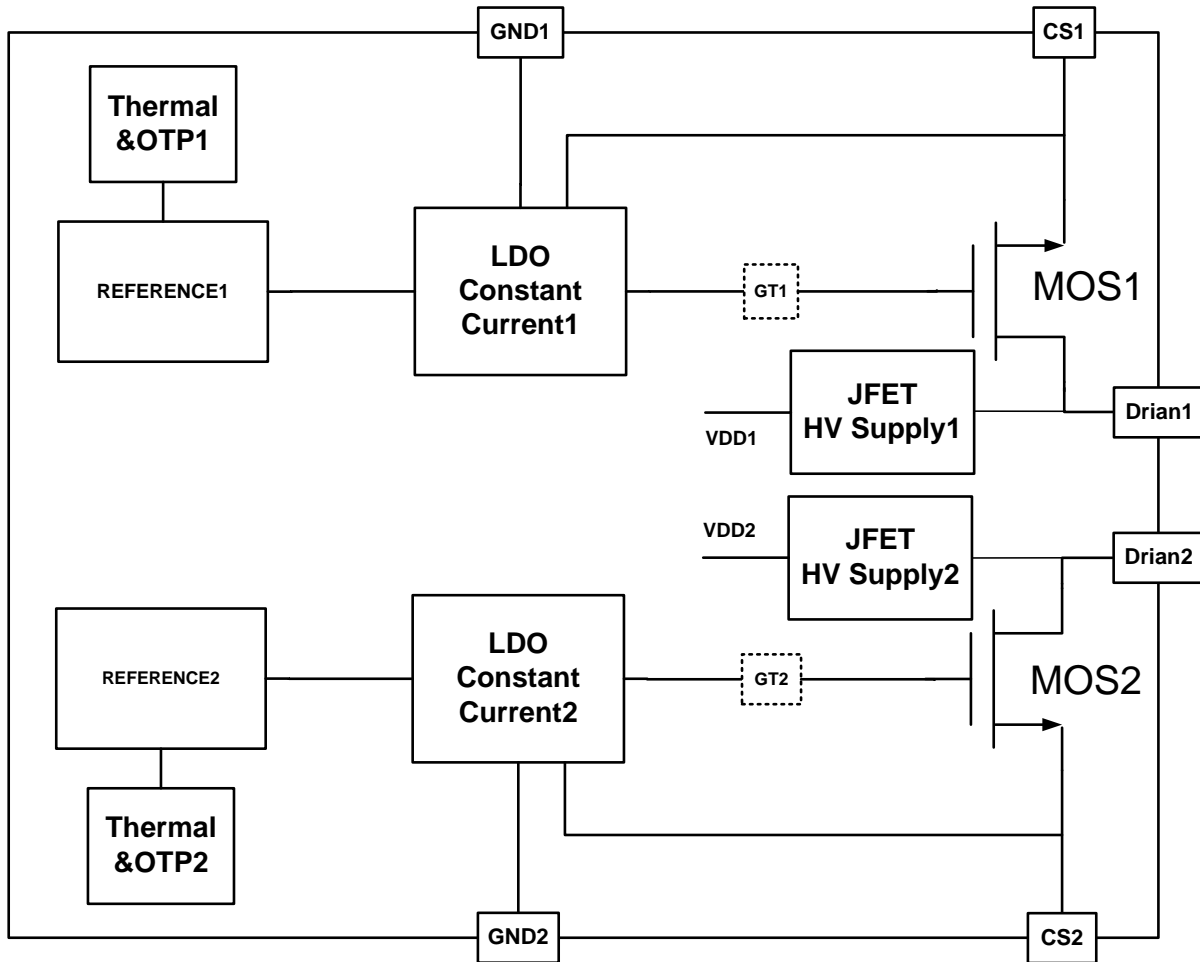

Fig3 DF6812E Block Diagram

Application Information

DF6812E is designed for linear driving LED strings with high forward voltage low LED current in line condition.

1 Supply

After system power on, the chip is supplied by JEFT through D, starting work once voltage on D above 10V.

2 Operation principle

DF6812E auto adjust the LED strings in working according to line voltage and extend the

LED working slots in every main cycles with purpose of output I_m maintenance and LED availability improvement. For different application, the forward voltage should match the input voltage to obtain higher efficiency, like 110V and 220V respectively.

3 Current configuration

DF6812E supports high precision LED current set by external resistors.

Current for LED string defined as:

$$I_{LED} = \frac{V_{ref}}{Rcs}$$

As recommended, in application case of 220V line condition, set the LED less than 40mA depend on thermal capability of heatsinking.

4 Thermal regulation

DF6812E has thermal regulation available on chip to balance the power delivering and temperature increasing. To improve the system reliability, the output current to be regulated lower down refer to the junction temperature.

5 PCB Layout design

Suggestion for DF6812E PCB layout:

GND1(2): Use the trace for current sense resistor as short as possible. Extend the copper area for D Pin to improve good thermal condition.

Heat sinking: DF6812E adopted ESOP8 package to strengthen the thermal dissipation, so that extend thermal pad for further.

Package

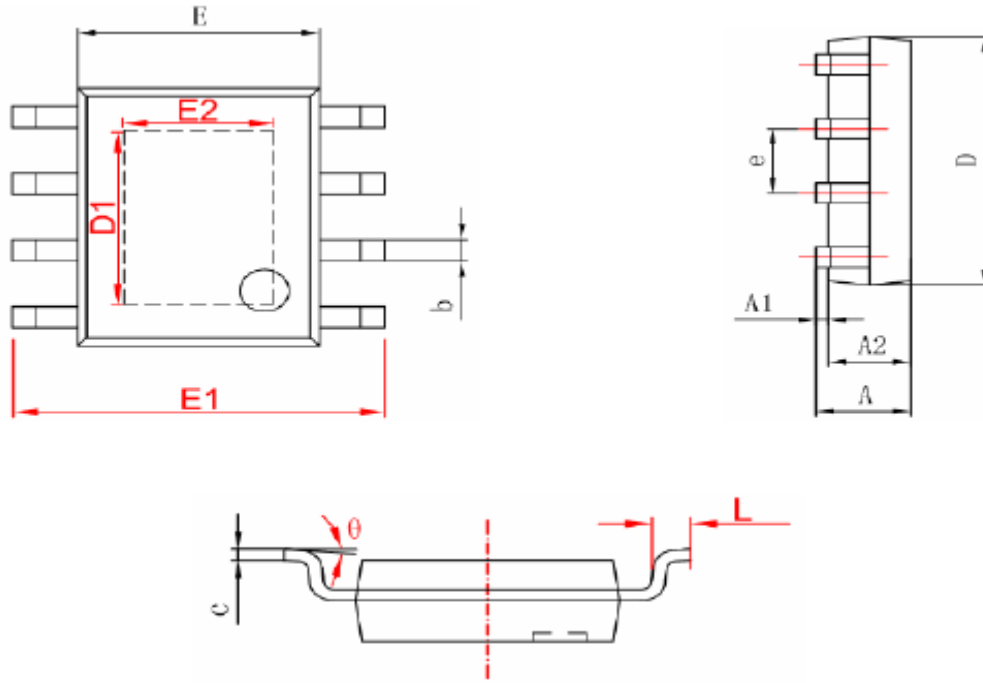

	MILLIMETERS		INCHES	
	MIN	MAX	MIN	MAX
A	1.350	1.750	0.053	0.069
A1	0.050	0.150	0.004	0.010
A2	1.350	1.550	0.053	0.061
b	0.330	0.510	0.013	0.020
c	0.170	0.250	0.006	0.010
D	4.700	5.100	0.185	0.200
D1	3.202	3.402	0.126	0.134
E	3.800	4.000	0.150	0.157
E1	5.800	6.200	0.228	0.244
E2	2.313	2.513	0.091	0.099
e	1.270(BSC)		0.050(BSC)	
L	0.400	1.270	0.016	0.050
θ	0°	8°	0°	8°